



IE Technologies (S) Pte Ltd

Automatic Battery Charger and Rectifier



IEC Series Battery Charger and Rectifier

- Single and Three Phase Input
- Constant Voltage
- Current Limiting
- Floor Standing or Wall Mount Cabinet

Understand the Technology of Power

IE Battery Charger and Rectifier

Content

Introduction	3
Rectification—Regulation	3
Technical Specification	4
Operation Mode	5
Control and Indication	6
Protection	7
Cubicle Construction Details	7
Additional Features	7
System Configuration	8



IE Battery Charger and Rectifier

Introduction

IEC Series

CUSTOM MADE BATTERY CHARGER
TO MEET CUSTOMER REQUIREMENTS

- Robust
- High Reliability
- Auto / Boost / Float Charging
- Regulated Output Voltage on Recharge
- Charger Malfunction Alarms

Applications:

- MV & HV Switchgear Tripping / Closing
- Emergency Lighting Systems
- Engine Starting
- Control and Monitoring Systems
- Public Address Systems
- Fire and Security Systems
- Telecommunication

Rectification—Regulation

IEC Battery Charger / rectifier offers a high degree of product customisation and is designed for long and high reliability. The charger / rectifier comprises of:-

- Main power transformer to adapt the mains to the battery voltage
- Half controlled bridge, consists of thyristors and diodes, rectifier and regulated DC voltage
- Filter components to smooth the DC output
- Input and output protection devices
- Electronic control circuit which regulates the output voltage and current by phase controlled switching of the thyristors / diode voltages
- Monitoring circuit which provides alarm indication.

IE Battery Charger and Rectifier

Technical Specification

Type of Charger

Current Limiting, Constant Voltage Charger with I-U Characteristic using thyristors as the regulated elements

AC Input

Model IEC-1 : Single Phase Input at 220—240 V or specified voltage
Frequency : 47Hz ~ 63Hz

Model IEC-3 : Three Phase Input at 380—415 V or specified voltage
Frequency : 47Hz ~ 63Hz

DC Output

Model : IEC-1 - Single Phase Input

Output Voltage	Output Current (Ampere, A)								
24V	5A	10A	15A	20A	30A	40A	60A	80A	
30V	3A	5A	10A	15A	20A	30A	40A	60A	
48V	5A	10A	15A	20A	20A	30A	40A	60A	
60V	5A	10A	15A	20A	20A	30A	40A	60A	
110V	5A	10A	15A	20A	20A	30A	40A	60A	
220V	5A	10A	15A	20A					

Other DC Voltages can also be requested.

DC Output

Model : IEC-3 - Three Phase Input

Output Voltage	Output Current (Ampere, A)								
24V	40	60	80	100	125	160	200		
48V	40	60	80	100	125	160	200		
110V	15	25	40	60	80	100	125	160	
	200	250	300	400					
220V	15	25	40	60	80	100	125	160	
	200	250	300	400					

IE Battery Charger and Rectifier

Operation Mode

Both the IEC-1 and IEC-3 battery chargers are Current Limiting Constant Voltage Type with an I-U Characteristics with the following mode of operation.

Automatic Mode

- Float at a Constant Voltage of 2.23 to 2.27 volt per cell for Lead Acid cell and 1.40 to 1.45 volt per cell for Nickel Cadmium cell
- Boost at a Constant Voltage of 2.30 to 2.45 volt per cell for Lead Acid cell and 1.50 to 1.65 volt per cell for Nickel Cadmium cell
- Automatic selection of the Float and Boost is under the control of an electronic control device accordingly to the following process:
 - A. Boost Charge is initiated automatically by the following conditions:
 - i. Initial switching on the charger
 - ii. Restoration of mains to the charger after Brown-out
 - iii. Battery falling below approximately 90% of the float voltage setting
 - B. Boost Charge is terminated automatically and float charge will be initiated in the following ways:
 - i. Charged battery prior to Boost initiation
The battery voltage reaches to approximately 90% of preset boost voltage level within a set time. The setting is controlled by the DIP switch setting.
 - ii. Fully or partially discharged battery prior to Boost initiation. If the battery voltage does not rise to 90% level within the preset timing, the Boost continues under voltage control until the battery voltage reaches 90% level. At this stage a Boost solid state timer is then activated which controls the Boost for a preset time to complete the charge

Manual Mode

Manual switching between Auto and Manual modes can be done by incorporating with a selector switch is mounted on the front of the panel or inside the cubicle.

Current Limit

In 'Float', 'Auto Boost' and 'Manual' modes, the maximum output current is limited 110% of the nominal charger current rating.

Ambient Temperature and Output Characteristics:

Normal Rating	:	at 45°C
De-rated to 70%	:	at 50°C
Operating Range	:	0°C ~ 50°C
Maximum Humidity	:	90% at 20°C
	:	80% at 25°C
	:	50% at 40°C

IE Battery Charger and Rectifier

DC Output Regulation : Output Voltage Regulation of $\pm 1\%$ and output current Stability of $\pm 2\%$ against simultaneous variation of:-
- load current 0% to 100%
- input voltage $\pm 10\%$ and frequency $\pm 5\%$

Float Voltage Range : Adjustable up to 125% of nominal voltage

Boost Voltage Range : Adjustable up to 140% of nominal voltage

Float Voltage Stability : $\pm 0.5\%$ from no-load to full load with AC input voltage Variation of $\pm 10\%$

Output Ripple Voltage : Less than 3% RMS value of the nominal DC voltage with battery connected having a capacity not less than 5 times of charger rated current

Current Stability : 1% at current limit

Overload Protection : Current limiting circuit provides protection down to Output short circuit, in boost and float operation

'Soft Start' Feature : 'Soft Start' feature provides sufficient time for the Current limit to operate on start up even under short Circuit condition

Control and Indication

Control - On the front of the cubicle door

- On / Off Circuit Breaker
- Voltmeter for Charger DC Voltage
- Ammeter for Charger Current

Indication - Alarm Sensing is fitted as standard with LED indicators to monitor the following functions:

- AC Supply On
- Mains Fail
- Charge Fail
- Boost Charge (Only applicable for Vented Lead Acid and Alkaline Nickel Cadmium Cell)
- Earth Fault (Only applicable for Floating System)
- Low Electrolyte Level (Only applicable for Alkaline Nickel Cadmium Cell)
- High Volt
- Low Volt
- Float Charge

Remote Indication

Facilities for General Remote Alarms monitoring is provided via a set of voltage free changeover contact

IE Battery Charger and Rectifier

Protection

- Input Circuit Breaker
- Surge Suppressor on Primary of Input Transformer
- High Speed Fuses for Semiconductors
- Circuit Auxiliary Fuses

Cubicle Construction Details

Control

Fold Steel Sheet construction with lockable hinged door

Ventilation

Natural Ventilation via louvers on the side of cubicle and grille at the base

Finishing

Textured finish to light grey or beige (RAL Colour Code)

Cable Entry

Bottom / Side entry or as specified

Protection

IP20 as standard. High Degree of IP protection can be provided upon request

Dimensions

Note that all cubicle are designed without battery compartment

Additional Features

Output Filtering

Feature Code : F1

Filtering to 1% RMS value output voltage with battery connected for telecommunication application

Individual Voltage Monitoring with Remote

Feature Code : F2

Alarm card providing individual indications come with remote monitoring

Function and fault conditions via one set of voltage free changeover contact:

- Mains Fail
- Charge Fail
- High Volt
- Low Volt

LED Lamp Test

Feature Code : F3

Push bottom for LED lamp test can be incorporated to provide the test for all LED indications on the front panel of cubicle

IE Battery Charger and Rectifier

Additional Features

Blocking Diode

Feature Code : F4

For parallel operation of charger with similar voltage and current

Dropper Diodes or Voltage Compensation

Feature Code : F5

A series regulator diodes connected to regulate the output load voltage to a specified tolerance within the customer load requirements

Battery Test

Feature Code : F6

The battery test (CTB) is for checking the condition of the battery without interruption of the load and Mains supply. This programmable battery test can be perform manual or automatic self test. The duration of the test can be preset and if the cells condition does not meet the requirement and fall below the threshold voltage, the battery fail alarm will be illuminated. Thus alarm can be latched-on or auto reset when the alarm clears. For latched-on condition, a reset signal is read to clear the alarm.

System Configuration

Example :

A system of Input Single Phase 230Vac and Output 110Vdc 10A with Output Filtering and LED Lamp Test.

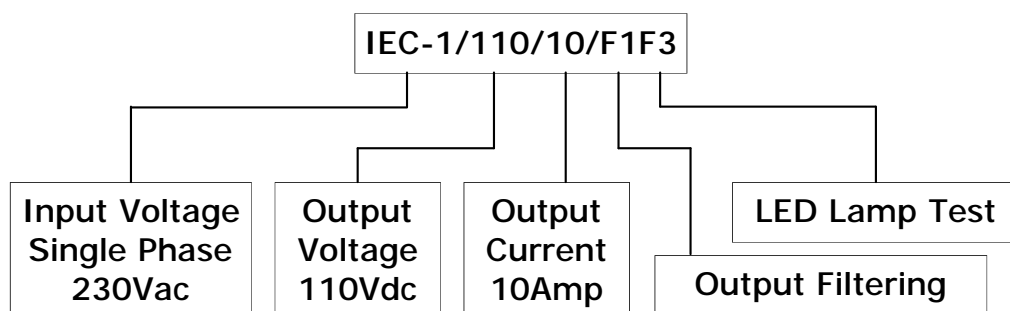

Authorised Distributor